







Gavita **ESA1** E-serie adapter

1 Introduction

Thank you for purchasing the Gavita ESA1 E-serie adapter. This manual describes the mounting and installing of the product. Mounting and installing of the Gavita ESA1 E-serie adapter may only be executed by certified service personnel. Please read and understand this manual completely before using the product. Only use the product as specified in this manual.

1.1 Used Symbols

-  **Warning!** A warning indicates severe damage to the user and/or product may occur when a procedure is not carried out as described.
-  **Caution!** A caution sign indicates problems may occur if a procedure is not carried out as described. It may also serve as a reminder to the user.
-  **Note:** A note gives additional information, e.g. for a procedure.
-  This symbol is an internationally recognized symbol used to designate recyclable materials.
-  With this symbol Gavita declares that this product complies with European requirements.
-  The symbol on the material, accessories or packaging indicates that this product may not be discarded as household waste. By properly disposing the equipment, you will be helping to prevent possible risks to the environment and public health, which might otherwise be caused by improper handling of the discarded equipment. Recycling of materials contributes to the conservation of natural resources. Therefore, please do not dispose of old electronics and electrical appliances via household waste.

2 Product description

The Gavita ESA1 E-serie adapter provides controllability for LED fixtures. It allows the user to connect multiple LED fixtures (sold separately) and control them simultaneously using a Gavita Master Controller (sold separately). The Gavita ESA1 E-serie adapter is intended to be used in greenhouses or in climate rooms. In this manual, the Gavita ESA1 E-serie adapter will be referred to as: "the E-serie adapter".

3 Product information and specifications

3.1 General product information

Product name	Gavita ESA1 E-serie adapter EU 240
Manufacturer	Hawthorne Gardening Company
Version	EU
Part number	HGC906154
EAN Code	8718403056440

3.2 Technical specifications

Product name	Gavita ESA1 E-serie adapter EU 240
Input voltage +/- 10%	230 - 240 VAC
Input current at 100%	3.3 A
Max LED fixture power	750 W
Dimensions (LxWxH)	290 x 65 x 77.5 mm
Operating temperature	0-45° C
Frequency	50/60 Hz
Certification standards	CE
Power inlet	Wieland RST 16i5 connector
IP rating	IP66
Power cord length	720 mm

3.3 Compatible products and accessories

Product	Product name	Gavita part number
Fixtures	Gavita Pro 1700 LED EU 240	HGC906059
	Gavita Pro 1700 LED UK 240	HGC906060
	Gavita Pro 1700 LED CH 240	HGC906065
	Gavita Pro 1700 LED ZA 240	HGC906067
	Gavita Pro 1700 LED AUS 240	HGC906068
Controllers	Gavita Master Controller EL1 EU/UK	HGC990786
	Gavita Master Controller EL2 EU/UK	HGC990789
	Gavita Master Controller EL1F EU/UK	HGC990792
	Gavita Master Controller EL2F EU/UK	HGC990794
Interconnect cables	Gavita Interconnect cable ESA RJ45-RJ45 10 ft/3.0m	HGC906711
	Gavita Controller cable ESA RJ45-RJ9 25 ft/7.5m	HGC906717
	Gavita Controller cable ESA RJ45-RJ9 10 ft/3.0m	HGC906716
	Gavita 3 way splitter ESA 1f to 2f RJ45	HGC906721

3.4 Environment

The product is intended to be used in greenhouses and climate rooms. The product can be used in wet environments. The product may not be used outdoors.

3.5 Legal

CE LVD approval according to: EN61347-1:2015, EN61347-2-11:2014+A1:2017

CE EMC approval according to: IEC61347-1:2015, IEC61347-1:2015/AMD1:2017, IEC61347-2-11:2001, IEC61347-2-11:2001/AMD:2017

4 Safety recommendations and warnings

⚠ Warning! Carefully read the warnings below before using or working with the product!

- Always adhere to the local rules and regulations when installing or using the E-series adapter.
- Do not open or disassemble the E-series adapter, it contains no serviceable parts inside. Opening or modifying the E-series adapter can be dangerous and will void the warranty.
- This product may cause interference to radio equipment and should not be installed near maritime safety communications equipment or other critical navigation or communication equipment operating between 0.45 - 30 MHz.
- Do not use the E-series adapter when either the E-series adapter or its power cord are damaged. Replace the power cord only with original certified cords.
- Modifications to the cords can lead to unwanted electromagnetic effects, which makes the product not comply with legal requirements.
- Place an over-current protection device (no greater than 16A) in series with the E-series adapter.
- Only connect the E-series adapter to a mains socket with a protective earth ground connection.
- Do not expose the E-series adapter to:
 - (ambient) temperatures outside the specified range;
 - dust and contamination;
 - direct sunlight during use or HID light that could heat up the ballast.
- Always disconnect the E-series adapter from mains before performing any maintenance.
- Always allow for a cool down period of at least 30 minutes before touching the E-series adapter. Touching the E-series adapter when the fixture is lit or immediately afterwards can result in severe burns!
- Do not use the E-series adapter near flammable, explosive or reactive substances. Do not use sulfur vaporizers or water misters.
- The installation and use of the E-series adapter is the responsibility of the end user. Incorrect use or installation can lead to failure and damage to the E-series adapter. Damage to the E-series adapter and electronic circuitry as a result of incorrect installation and use revokes the warranty.

5 Contents (1)

- A. Wieland RST 16i5 male connector
 1. Output
 2. Input
- B. Gavita RJ45 female connector
 1. Output
 2. Input
- C. Wieland RST 16i5 female connector
- D. Waterproof plug (2x)
- E. Dummy plug
- F. RJ45 connector sleeve (2x)
- G. Interconnect cable ESA RJ45 - RJ45 3.0 m
- H. Controller cable ESA RJ45-RJ9 3.0 m
- I. LED indicator

OPTIONAL:

- 3 way splitter

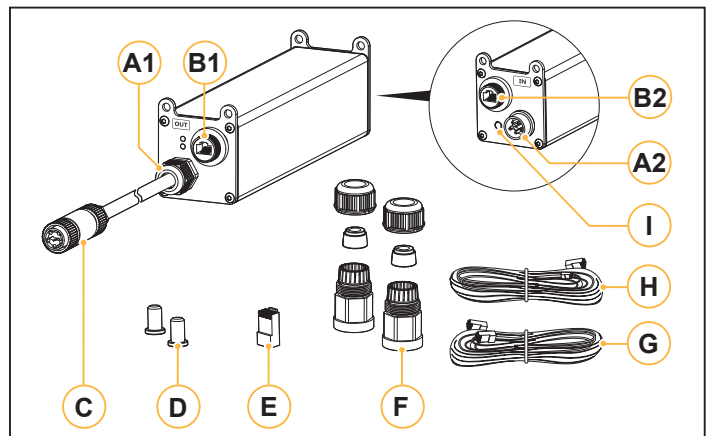

1.

6 Installation

- ⚠ **Warning!** Mounting and installing of the E-series adapter(s) may only be executed by certified service personnel, in accordance with the applicable local laws and regulations.
- ⚠ **Warning!** The installer is responsible for correct and safe installation.
- ⚠ **Warning!** Ensure the local cabling can support the voltage and current requirements of the E-series adapter and LED fixture.
- ⚠ **Warning!** Avoid coiled cords and keep mains leads separated. This prevents electromagnetic interference.
- ⚠ **Warning!** Do not connect or disconnect the E-series adapter under load.

Using a daisy chain setup, a maximum of 100 E-series adapters can be connected to one controller. Up to 500 E-series adapters per daisy chain can be connected when using splitters. See section 6.2 and 6.3 of this manual and the manual of the controller.

6.1 Installing an interconnect or controller cable with the RJ45 connector sleeve

Follow the steps below to connect an interconnect cable or controller cable to the E-series adapter.

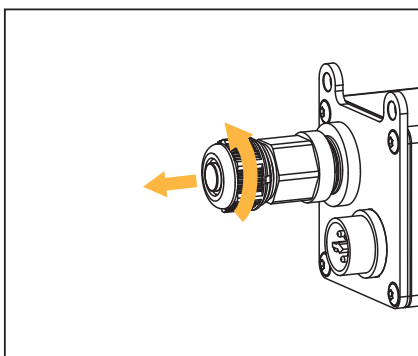

2.

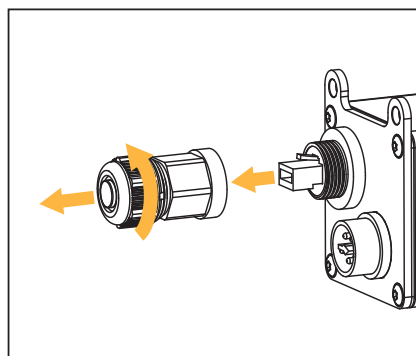

3.

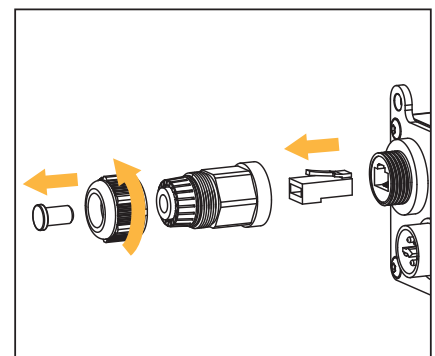

4.

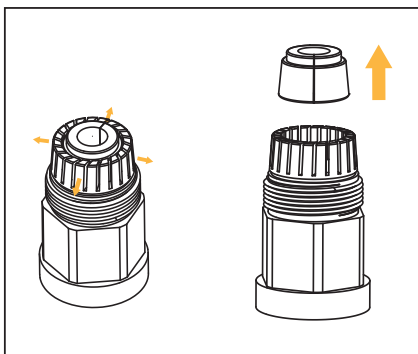

5.

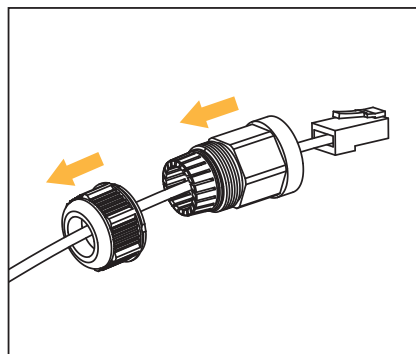

6.

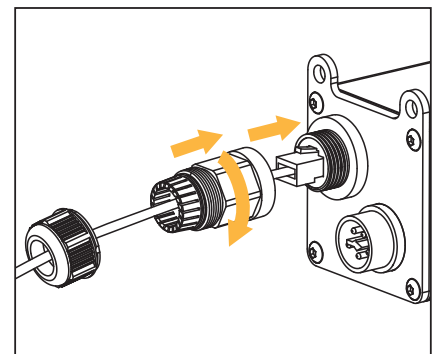

7.

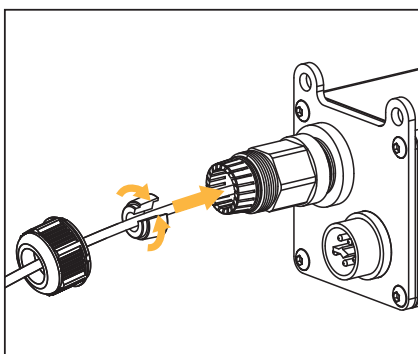

8.

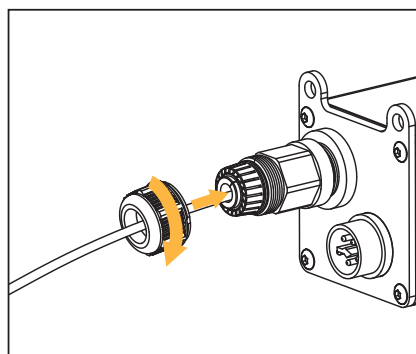

9.

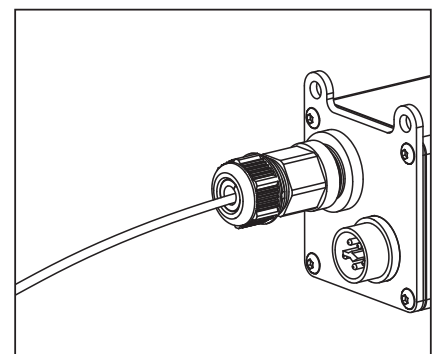

10.

6.2 Connecting up to 100 E-series adapters

- Remove the dummy plug (part E) from the RJ45 input port (part B2) on the first E-series adapter (fig. 2-4).
- Use the controller cable (RJ45 - RJ9) (part H) to connect the RJ45 input port on the first E-series adapter to the RJ9 output port of the Master Controller (fig. 5-10 and 11A).
- Remove the dummy from the RJ45 input port on the second E-series adapter (fig. 2-4).
- Use the interconnect cable (RJ45 - RJ45) (part G) to connect the RJ45 output port (part B1) of the first E-series adapter to the input port of the second E-series adapter (fig. 5-10 and 11B).

⚠ Caution! Always use the RJ45 connector sleeves to protect the connectors from dust and water.

- Repeat these steps to connect up to 100 E-series adapters (fig. 10C).

⚠ Warning! Ensure the power cord and the interconnect and controller cables do not touch any of the LED fixtures.

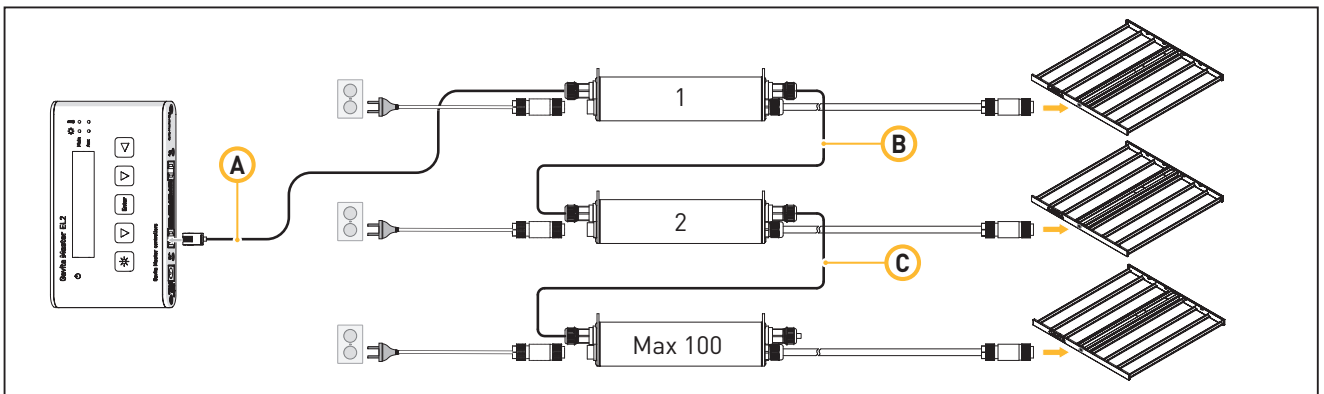

11.

6.3 Connecting up to 500 or 1000 E-series adapters

Using a setup with daisy chained splitters, up to 500 E-series adapters on EL1 and 1000 E-series adapters on EL2 (over two channels) can be connected as shown in fig. 12.

- Use the controller cable (RJ45 - RJ9) (part H) to connect the primary channel of the controller to the input port of the first two-way splitter (sold separately) (fig. 12A).
- Remove the dummy from the input port of the E-series adapter (fig. 2-4).
- Use the interconnect cable (RJ45 - RJ45) (part G) to connect the RJ45 output port of the splitter to the RJ45 input port (part B2) of the first E-series adapter (fig. 12C).
- Use the interconnect cable (RJ45 - RJ45) (part G) to connect the RJ45 output port (part B1) of the first E-series adapter to the input port of the second E-series adapter (fig. 5-10 and 11B).
- Repeat these steps to connect up to 100 E-series adapters per splitter output port (fig. 12E). Up to 500 E-series adapters can be connected to the primary channel.
- Use the interconnect cable (RJ45 - RJ45) (part G) to connect the output of a splitter to the input port of the next splitter (fig. 12F).
- Use the secondary channel (fig. 12G) to connect another 500 E-series adapters in the same way.

- ⚠ **Warning!** Ensure the power cord and the controller cables do not touch the LED fixtures.
- ⚠ **Warning!** Distribute number of E-series adapters evenly over daisy chains.
- ⚠ **Warning!** Ensure the repeater bus connections are integrated in a correctly set up installation for best results.
- ⚠ **Warning!** Boosters should never be used to expand.
- ⚠ **Warning!** The maximum cable length per splitter is 250m (100 interconnect cables).

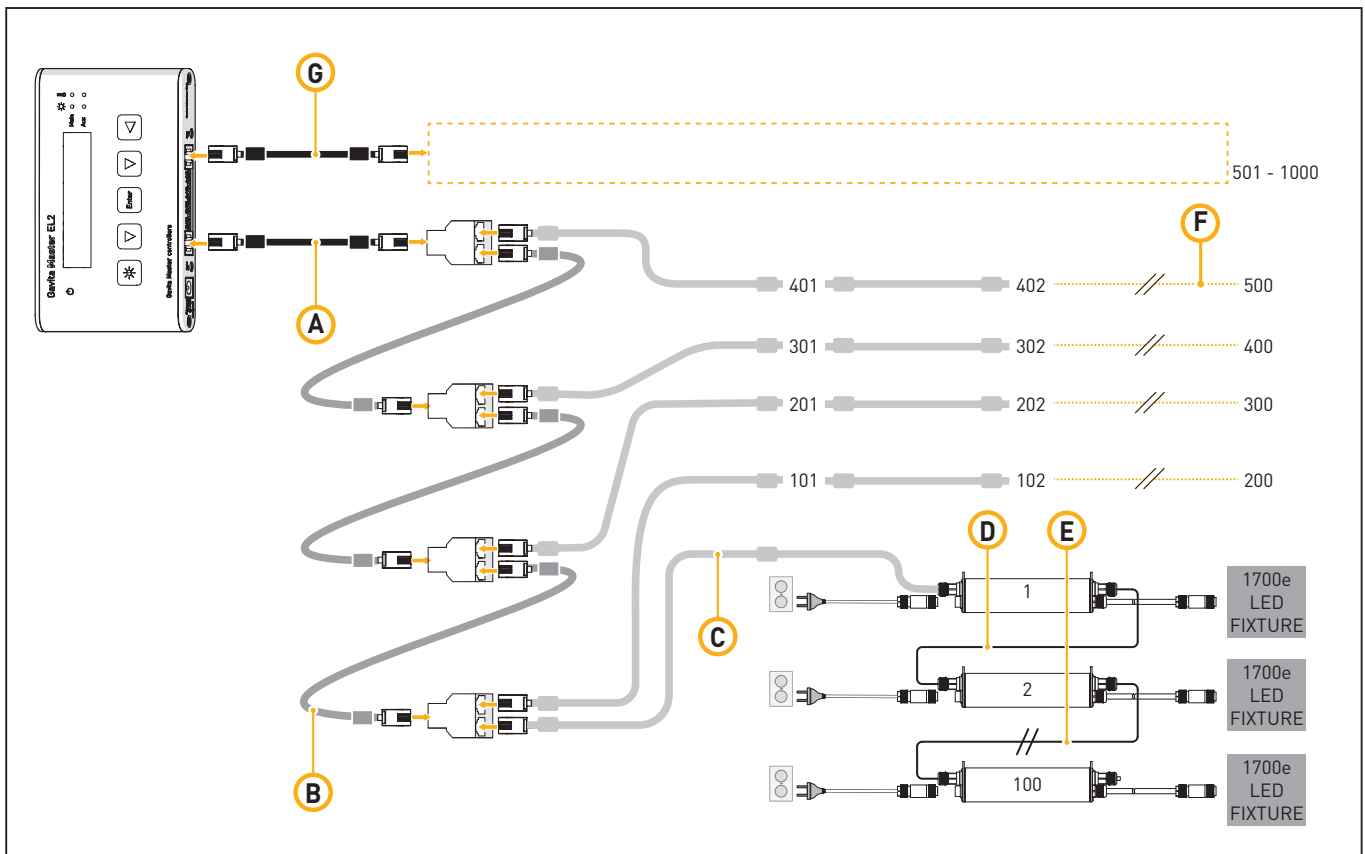

12.

7 Inspection, maintenance and repair

- ⚠ **Warning!** Disconnect the E-series adapter from the mains before performing any maintenance or repairs.
 - ⚠ **Warning!** Do not connect or disconnect the E-series adapter under load.
 - ⚠ **Warning!** Do not open or disassemble the E-series adapter, it contains no serviceable parts inside. Opening the E-series adapter can be dangerous and will void the warranty.
 - ⚠ **Warning!** Always allow for a cool down period of at least 30 minutes before touching the E-series adapter.
 - ⚠ **Caution!** Do not clean the E-series adapter with detergents, abrasives or other aggressive substances.
- Regularly check the E-series adapter for dust or dirt buildup. Clean if necessary. Contamination may cause overheating and decreased performance. Clean the outside of the E-series adapter using a dry or damp cloth.
 - Regularly check the cables of the E-series adapter to ensure it is undamaged.

7.1 How to disconnect the Wieland RST16i5 plug

⚠ **Warning!** Do not connect or disconnect the Wieland RST16i5 plug under load.

- Switch off mains power.
- Turn the ring on the Wieland RST16i5 female connector counterclockwise and pull the Wieland RST16i5 female connection from the E-series adapter (fig. 15).

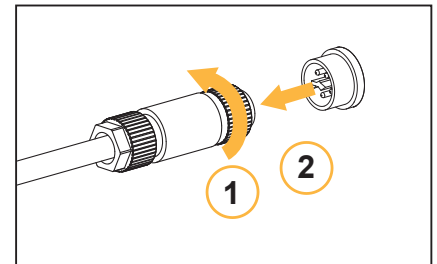

13.

8 Storage and disposal

- Store the E-series adapter in a dry and clean environment, with an ambient temperature of -10~40° C.
- The product must not be discarded as unsorted municipal waste, but must be collected separately for the purpose of treatment, recovery and environmentally sound disposal.

9 Warranty service

Gavita International b.v. warrants the mechanical and electronic components of their product to be free of defects in material and workmanship if used under normal operating conditions for a period of three (3) years from the original date of purchase. If the product shows any defects within this period and that defect is not due to user error or improper use Gavita International b.v. shall, at its discretion, either replace or repair the product using suitable new or reconditioned products or parts. In case Gavita International b.v. decides to replace the entire product, this limited warranty shall apply to the replacement product

for the remaining initial warranty period, i.e. three (3) years from the date of purchase of the original product. For service return the Gavita ESA1 E-series adapter to your shop with the original sales receipt.



Manual: Gavita ESA1 E-serie adapter EU
Changes reserved - Version 20/23
Not for sale or use in the Netherlands

GAVITA International bv
Oosteinderweg 127
1432 AH Aalsmeer
The Netherlands

Tel: +31(0)297-380 450
Fax: +31(0)297-380 451
E: info@gavita.com
W: www.gavita.com